

C124

DECOM ENGINEERING C1-24 CHOPSAW

Topside or ROV operated cutting tool

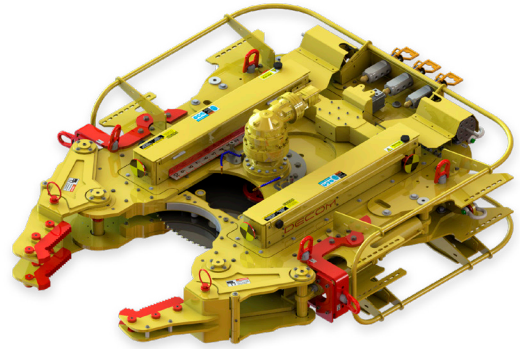

APPLICATIONS

- Pipe - coated or bare
- Jacket structures, box sections etc.
- Casing
- Mooring chain
- Solid bars
- Umbilicals and cable

FEATURES

- 2" to 24" capacity
- Fast and clean cut
- Market leading cut times
- Multiple cuts per blade: up to 100 depending on application
- Topside or ROV operated
- Operator-friendly control panel
- Robust shipping cage with comprehensive spares boxes
- Highly adaptable to suit surroundings and structures
- Multiple lifting points located around the tool allowing a highly versatile angle of deployment

The Decom Engineering C1-24 Chopsaw has been designed to cut tubulars and other materials from 2" to 24". Its innovative design has produced market leading cut times across a wide range of materials including inconels, duplex, concrete and more.

PRODUCT BENEFITS

- Multiple cuts per blade, anywhere from 20 right up to 100 cuts per blade, application dependent - thus resulting in large cost savings and increases in efficiencies.
- Can complete an array of cuts whilst subsea or held in wet storage - without returning to the surface.
- Chopsaw comes with a comprehensive spares package, in a compact yet robust shipping cage.
- Unique water cooling system for surface cutting.
- The C1-24 Chopsaw can be supplied set up in a number of configurations and settings to suit project requirements and work scope.
- Customisable clamping system allowing the flexibility to clamp around a vast array of shapes and sizes.
- Blade change only takes 10 -15 minutes.
- Can cut vertically or horizontally.

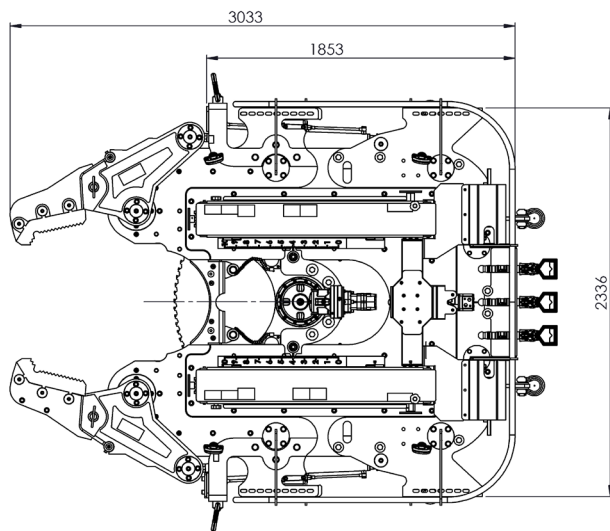
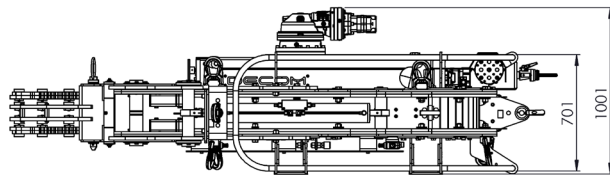

C1-24" Saw Specification	
Cutting capability	2" - 24" (50mm - 610mm)
Hydraulic requirements	100 L/min @ 210 bar
Weight in air	3,800kg
Weight in water (with buoyancy module)	100kg
Dimensions	3033mm x 2236mm x 1002mm
Blade	1520mm
Nominal RPM	27